

# BAUM SINGLE SPINDLE DRILLS

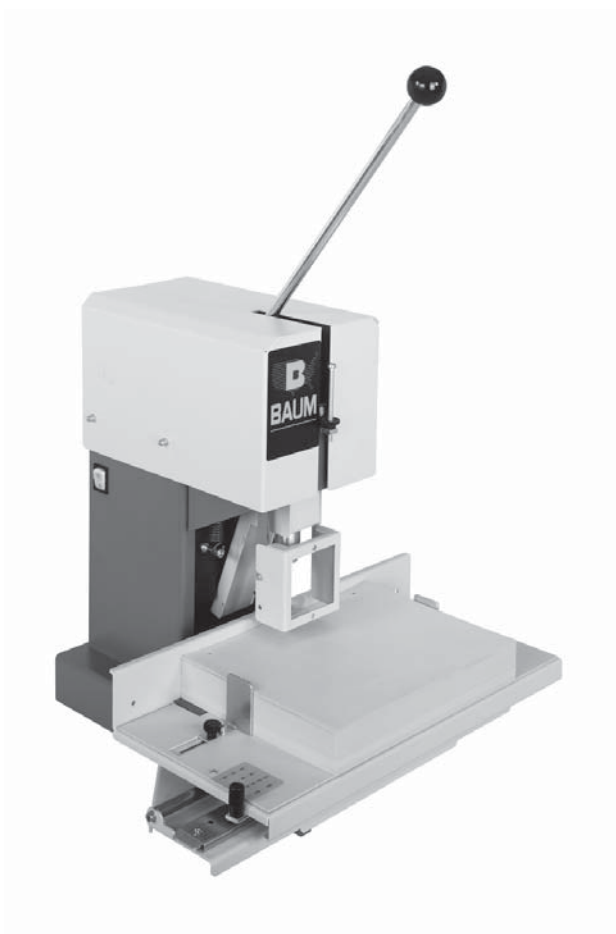
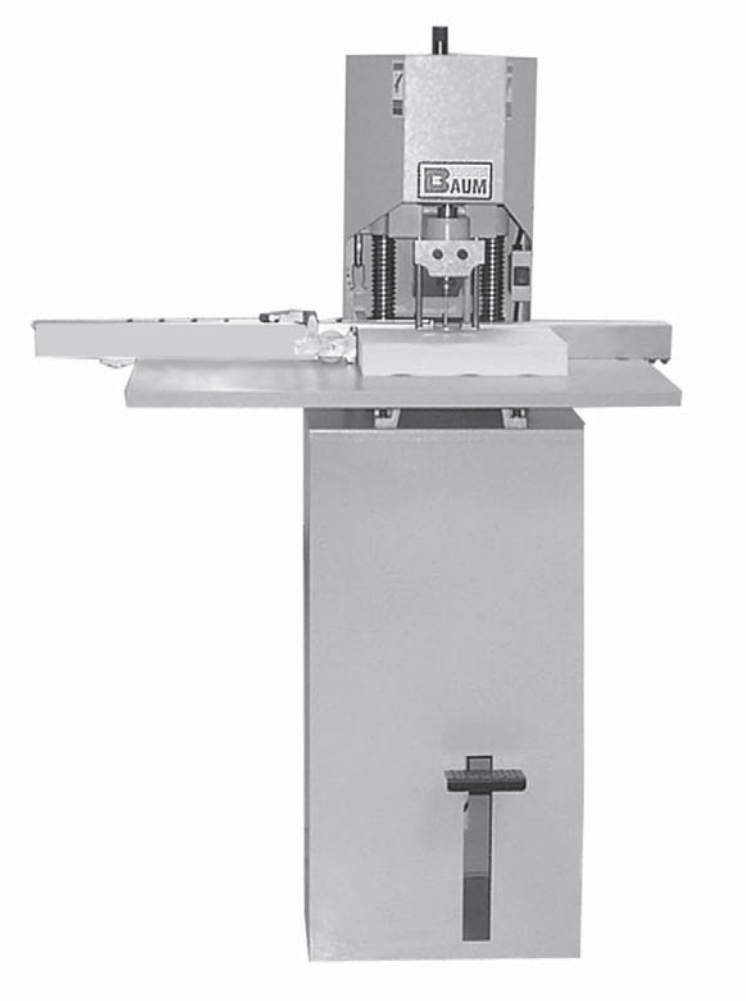

# Baum Single Spindle Drills

The Baum 1NT Single Spindle Tabletop and Baum 1F Single Spindle Floor Model paper drills can be used for a wide variety of drilling applications for commercial, in-plant, small printers, financial institutions, schools, offices and much more. Features include:

- Automatic chip disposal. The chips of paper cut out by the hollow drill travel up through the drill and drop onto a removable waste bin inside the machine.
- Drill a two-inch lift in one stroke. 1/4" to 1/2" drills have two-inch capacity. Smaller diameter drills will do lifts from 5/8" to 1-5/8" depending on the size.
- Uses Baum ND drill bits.

## Baum 1NT

- Centering side guides
- Simple and safe operation
- Traversing table
- Preset drilling patterns
  - 3-hole 4-1/4" centers
  - A4 and A5 2-hole 80mm centers
  - A4 ring binder 4-hole 45/65/45mm
  - 6-hole Filofax Time Planner [19/19/50/19/19mm centers]



## Baum 1F

- Adjustable, automatic trip side guide
- Manual foot pedal operation
- Drilled hole sizes from 1/8" to 1/2"
- [7] Adjustable stops for a wide variety of drilled hole patterns

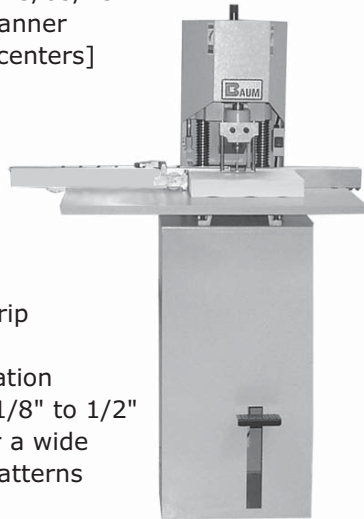

## Baum 1NT

## Specifications

Max lift height .....	2" [5cm]
Max sheet size .....	13.7" x 9.8" [350 x 250cm]
Max margin distance .....	1.1" [28mm]
Drill bit diameters .....	1/8" to 3/8" [3 - 9mm]
Drill operation .....	Manual hand lever
Min distance between holes .....	Infinite
Max center to center .....	11.38" [28.9cm]
Net weight .....	58 lbs [26kg]
Shipping weight .....	67 lbs [30kg]
Electrical .....	110V/1ph/60Hz 1.3 amps
Overall dimensions ..	12.2"h x 12"w x 12"d [48 x 47 x 47cm]
Standard accessories .....	[1] Drill bit, drilling boards, .....
	lubrication strips for drill bits, [1] horseshoe retainer
Optional accessories .....	Hollow drill bit sharpener, .....
	Teflon coated drill bits, lubricant sticks

## Baum 1F

## Specifications

Max lift height .....	2" [5cm]
Max margin distance .....	4" [10.16cm]
Drill bit diameters .....	1/8" to 1/2" [3 - 12.7mm]
Drill operation .....	Manual foot lever
Min distance between holes .....	0.38" [9.7mm]
Max center to center .....	18.5" [470cm]
Net weight .....	154 lbs [70kg]
Shipping weight .....	225 lbs [102kg]
Electrical .....	110V/1ph/60Hz 5.3 amps
Overall dimensions ..	60"h x 42"w x 32"d [142 x 107 x 81cm]
Standard accessories .....	Hollow drill bit sharpener, tool kit, .....
	[1] 5/16" diameter drill bit, [4] wood drilling blocks

Note: Specifications subject to change without notice.

Internet: <http://www.baumfolder.com> • e-mail: [BAUM@bright.net](mailto:BAUM@bright.net)



1660 Campbell Rd. • Sidney, Ohio 45365  
 Phone 937/492-1281 or 800/543-6107  
 Fax 937/492-7280

Authorized Distributor: